

CONSEW[®]

PARTS LIST

パーツリスト

255RBL-25

339RBL-25

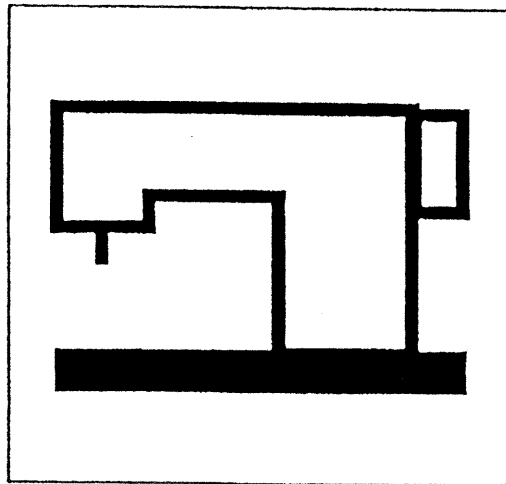

CONSOLIDATED SEWING MACHINE CORP.
U.S.A · JAPAN

INDEX

	Pages
面板、上板.....	1. 2
FACE PLATE, ARM TOP COVER	
天ビン、上軸、プーリ.....	3. 4
TAKE UP LEVER, ARM SHAFT, MACHINE PULLEY	
押工棒、中押工棒.....	5. 6
PRESSER BAR, VIBRATING PRESSER BAR	
針棒土台、連結ロッド.....	7. 8
NEEDLE BAR ROCK FRAME, ROCK SHAFT CRANK CONNECTION	
大弓、押工棒大板バネ.....	9. 10
KNEE LIFTER LIFTING LEVER, PRESSER BAR SPRING	
下軸、下ベルトプーリー送りカム.....	11.12
HOOK DRIVING SHAFT, SAFETY CLUTCH PULLEY, FEED DRIVING CAM	
針板、送り土台、送り軸.....	13.14
THROAT PLATE, FEED BAR, FEED ROCK SHAFT	
バックレバー、下送りロッド.....	15.16
FEED REVERSING LEVER, FEED DRIVING ECCENTRIC CONNECTION	
カム土台、カム.....	17. 18. 19. 20
HOOK SADDLE, HOOK	
調子板.....	21. 22
TENSION	
給油.....	23. 24
LUBRICATION	
附属品.....	25. 26
ACCESSORIES AND ATTACHMENTS	
別売品.....	27. 28
PARTS AVAILABLE AT EXTRA CHARGE	

面板、上板
FACE PLATE ARMTOP COVER

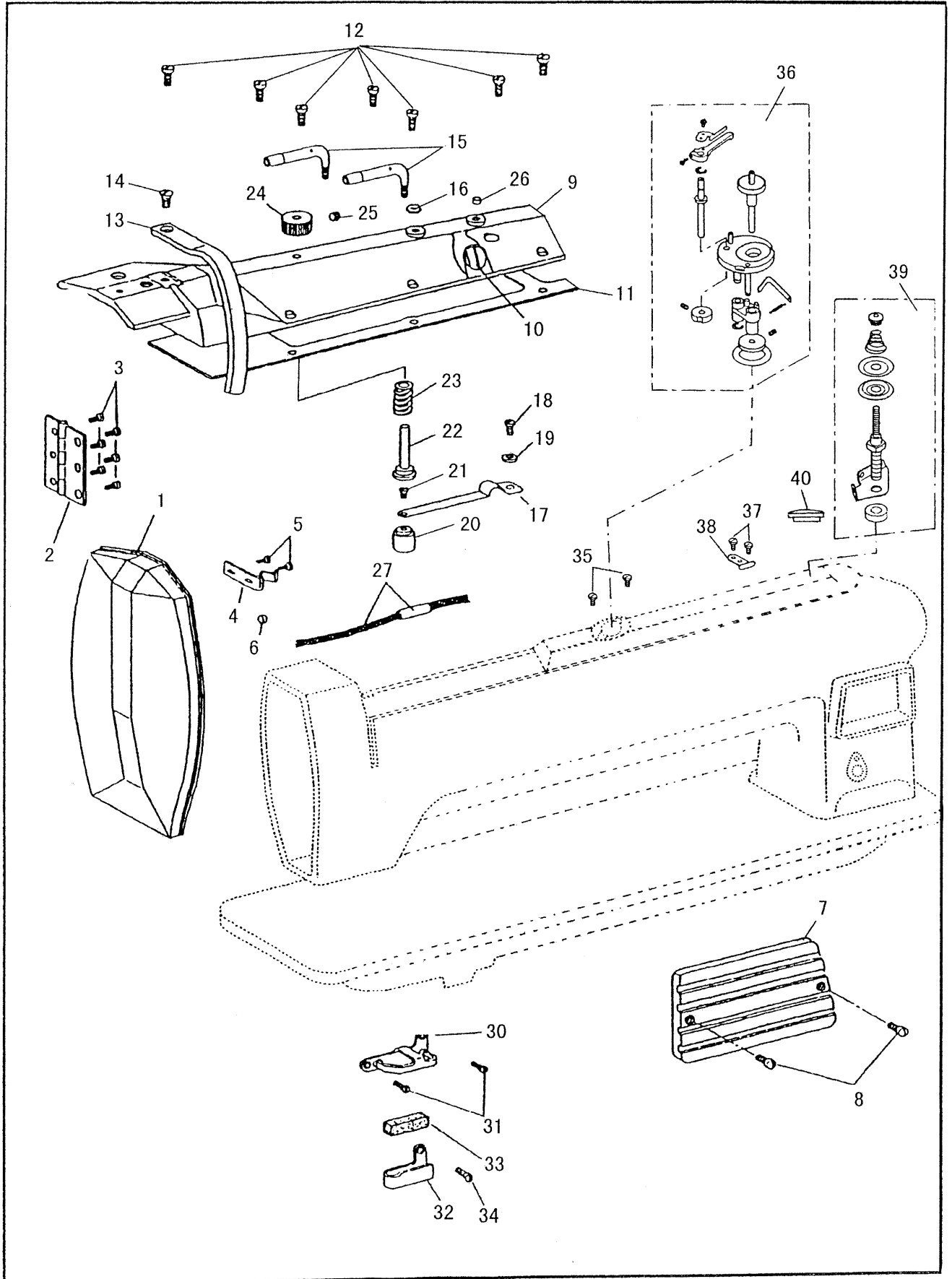

面板、上板
FACE PLATE、ARM TOP COVER

NO	部品番号 PART NO	339RBL -25	255RBL -25	数量 QTY	品名	PARTS NAME
1	15035	*	*	1	面板	FACE PLATE
2	15036	*	*	1	蝶番	HINGE
3	15039	*	*	6	止めねじ	SCREW 1/8X44 L=3.5
4	15037	*	*	1	面板ばね	FACE PLATE SPRING
5	15039	*	*	2	止めねじ	SCREW 1/8X44 L=3.5
6	15038	*	*	1	面板ゴム	RUBBER
7	13556	*	*	1	横板	ARM TOP COVER
8	8040	*	*	2	止めねじ	SCREW 9/64x40 L=8.0
9	81001-L	*	*	1	上板	ARM TOP COVER
10	11007	*	*	1	油量覗き窓	OIL LEVER INDICATOR
11	81002-L	*	*	1	上板ミートパッキン	GASKET
12	15007	*	*	7	止めねじ	SCREW 9/64x40 L=10.0
13	36708	*	*	1	天秤カバー	THREAD TAKE UP COVER
14	6031-02	*	*	1	止めねじ	SCREW 11/64x40 L=9.0
15	11006	*	*	1	上板系掛	ARM TOP COVER THREAD GUIDE
16	13076-02	*	*	1	ナット	NUT 7/32X32
17	15086	*	*	1	油調節板ばね	OIL CONTROL SPRING
18	8040	*	*	1	止めねじ	SCREW 9/64x40 L=8.0
19	11142	*	*	1	ワッシャー	WASHER
20	11004	*	*	1	油調節おもり	OIL REGULATOR
21	10597	*	*	1	止めねじ	SCREW 1/8x40 L=3.3
22	15058	*	*	1	給油遮断軸	OIL REGULATING STUD
23	15059	*	*	1	給油遮断スプリング	OIL REGULATING SPRING
24	15057	*	*	1	給油遮断ダイヤル	OIL REGULATING DIAL
25	8009	*	*	1	止めねじ	SET SCREW 15/64X28 L=7.5
26	15038	*	*	1	上板ゴム栓	RUBBER
27	15034C	*	*	1	ビニールチューブ、油芯(組)	OIL TUBE AND OIL WICK COMPLETE
28						
29						
30	15054	*	*	1	面系掛け(上)	THREAD GUIDE (UPPER)
31	10685	*	*	2	止めねじ	SCREW 3.4x36 L=6.5
32	10759-A	*	*	1	面系掛け(下)	THREAD GUIDE (LOWER)
33	10760	*	*	1	面系掛けフェルト	FELT
34	10685	*	*	1	止めねじ	SCREW 3.4x36 L=6.5
35	81003-L	*	*	2	止めねじ	SCREW 11/64x40 L=8
36	81004-L	*	*	1	系巻き組立	BOBBIN WINDER COMPLETE
37	81005-L	*	*	2	止めねじ	SCREW 9/64x40 L=4.5
38	81006-L	*	*	1	糸きりホジボン	THREAD CUTTER
39	81007-L	*	*	1	チヨウセツキ組立	THREAD TENSION REGULATOR ASSY
40	81008-L	*	*	1	セン φ19	RUBBER PIUG φ19

天ビン、上軸、プーリー

TAKE UP LEVER, ARM SHAFT, MACHINE PULLEY

NO	部品番号 PART NO	339RBL -25	255RBL -25	数量 QTY	品名	PARTS NAME
1	82001-L	*	*	1	上軸	ARM SHAFT
2	15033	*	*	1	上軸油芯	OIL WICK
3	10506	*	*	1	上軸油栓ねじ	OIL STOP SCREW 7.85X20 L=8.0
4	10577	*	*	1	プーリー押しねじ	PULLEY ADJUSTING SCREW 6.75X24 L=11.0
5	19414	*	*	1	クランクモーションカム	NEEDLE BAR CRANK
6	19415	*	*	1	位置決めねじ	POSITION SCREW 1/4X28 L=20.0
7	19416	*	*	1	止めねじ	SET SCREW 1/4X28 L=14.0
8	10563	*	*	1	上軸メタル(前)ワッシャ	WASHER
9	10562	*	*	1	上軸メタル(前)	ARM SHAFT BUSHING (LEFT)
11	10524	*	*	1	止めねじ	SET SCREW 6.75X24 L=6.5
13	10725	*	*	2	上軸メタル(前)フェルト	OIL FELT
14	13074	*	*	1	上軸ベアリングケース	ARM SHAFT BALL BEARING ADAPTOR
15	10567	*	*	1	上軸ベアリング	ARM SHAFT BALL BEARING
16	13361	*	*	1	上軸ベアリングカラー	ARM SHAFT BALL BEARING ADAPTOR SLEEVE
17	19418	*	*	2	止めねじ	SET SCREW 1/4X28 L=4.5
18	10568	*	*	1	溝なしリング	BALL BEARING RETAINING RING
19	10571	*	*	1	上軸ベアリングケース止めねじ	SCREW 6.75X24 L=20.0
20	10504	*	*	1	プーリー	MACHINE PULLEY
21	10943	*	*	1	文字リング	FEED INDICATING (W/O BELT GUARD)
22	10566	*	*	1	文字リングねじ	SET SCREW 1/4X32 L=5.5
23	10576	*	*	1	位置決めねじ	POSITION SCREW 15/64X28 L=21.0
24	10579	*	*	1	止めねじ	SET SCREW 15/64 X28 L=20.0
25	10569	*	*	1	ベルトプーリー	ARM SHAFT CONNECTING BELT PULLEY
26	10574	*	*	2	ベルトプーリーリング	BELT PULLEY SPRING FLANGE
27	10571-G	*	*	1	ベルトプーリー止めねじ	SET SCREW 6.75X24 L=20.0
28	10570	*	*	1	ベルトプーリーピンねじ	POSITION SCREW 6.75X24 L=14.5
29	10524-G	*	*	1	ベルトプーリーピンねじ止めねじ	POSITION SCREW SET SCREW 6.75X24 L=6.5
30	10621	*	*	1	タイミングベルト	ARM SHAFT CONNECTING BELT
32	15024C	*	*	1	天秤(組)	THREAD TAKE UP LEVER COMPLETE
32	15024	*	*	1	天秤	THREAD TAKE UP LEVER
33	15026	*	*	1	天秤抱き	THREAD TAKE UP LEVER DRIVING STUD
34	10728	*	*	1	天秤抱き油芯	OIL WICK
35	10528	*	*	1	針棒クランク	NEEDLE BAR CONNECTING LINK
36	15013	*	*	1	天秤ピン	THREAD TAKE UP LEVER HINGE STUD
37	11042	*	*	1	天秤ピン油芯	OIL WICK
38	10524	*	*	1	天秤ピン止めねじ	SET SCREW 6.75X24 L=6.5
39	10523	*	*	1	針棒クランクピン	NEEDLE BAR CONNECTING LINK STUD
40	10726	*	*	1	針棒クランクピン油芯	OIL WICK
41	15038	*	*	1	油ゴム栓	RUBBER OIL STOPPER
42	19417	*	*	1	針棒クランクピン止めねじ(長)	SCREW 1/4X28 L=6.5
43	19418	*	*	1	針棒クランクピン止めねじ(短)	SCREW 1/4X28 L=4.5
44	10551	*	*	1	天秤油受け	THREAD TAKE UP LEVER OIL GUARD
45	10650	*	*	1	天秤油受け止めねじ	SCREW 3.4X36 L=6.0
46	10772C	*	*	1	上連結ロッド	LIFTING ECCENTRIC CONNECTING COMPLETE
47	10772	*	*	1	上連結ロッド	LIFTING ECCENTRIC CONNECTION
48	10773	*	*	1	二ードルベアリング	NEEDLE BEARING
49	19427	*	*	1	中押え上下カム	LIFTING ECCENTRIC
50	19508	*	*	2	中押え上下カム止めねじ	SET SCREW 1/4X40 L=5.5
51	11879	*	*	1	中押え上下カムカラー	LIFTING ECCENTRIC COLLAR
52	10573	*	*	2	中押え上下カムカラー止めねじ	SET SCREW 7/32X32 L=11.0

押工棒、中押工棒

PRESSER BAR、VIBRATING PRESSER BRA

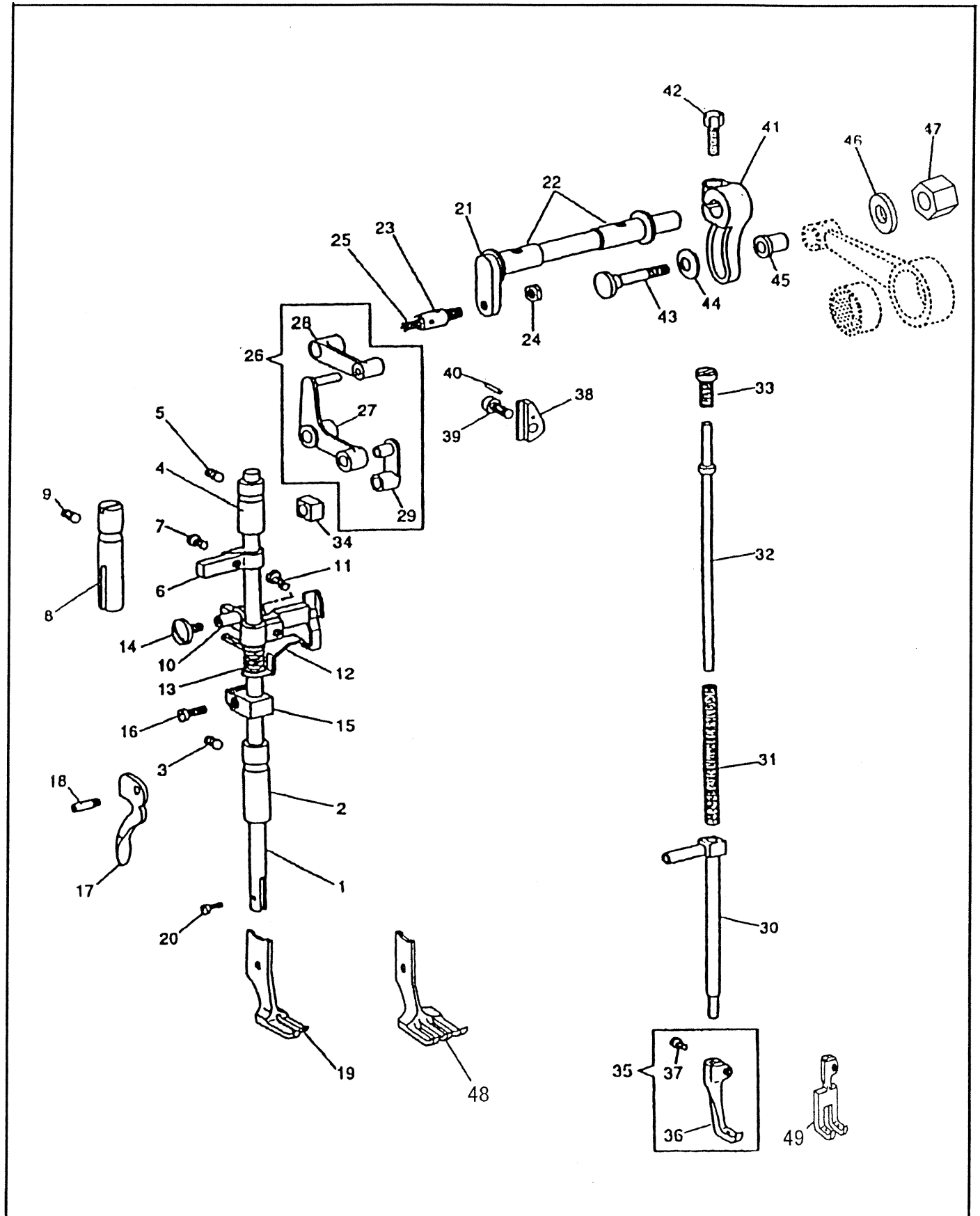

押工棒、中押工棒

PRESSER BAR、VIBRATING PRESSER BAR

NO	部品番号 PART NO	339RBL -25	255RBL -25	数量 QTY	品名	PARTS NAME
1	10540	*	*	1	押え棒	PRESSER BAR
2	10539-A	*	*	1	押え棒(下)メタル	PRESSER BAR BUSHING (LOWER)
3	10761	*	*	1	止めねじ	SET SCREW 6.75×24 L=11.0
4	10538	*	*	1	押え棒(上)メタル	PRESSER BAR BUSHING (UPPER)
5	10761	*	*	1	止めねじ	SET SCREW 6.75×24 L=11.0
6	10541	*	*	1	押え棒案内	PRESSER BAR POSITION GUIDE BRACKET
7	10862	*	*	1	止めねじ	SCREW 5/32×40 L=6.5
8	10543	*	*	1	案内棒	PRESSER BAR POSITION GUIDE
9	10761	*	*	1	止めねじ	SET SCREW 6.75×24 L=11.0
10	18479	*	*	1	押え棒抱き	PRESSER BAR LIFTING BRACKET
11	19518	*	*	1	押え棒抱き締めねじ	SCREW 11/64×40 L=14.0
12	10548-A	*	*	1	押え棒抱き下板	TENSION RELEASE SLIDE
13	10547	*	*	1	押え棒抱き下板ばね	TENSION RELEASE SPRING
14	18480	*	*	1	くの字止めねじ	LIFTING BELL CRANK SCREW 11/64×40 L=8.0
15	13360	*	*	1	押え棒抱きリング	PRESSER BAR SPRING BARCKET
16	13365	*	*	1	押え棒抱きリング締めねじ	PINCH SCREW M4X0.7 L=9.0
17	10659	*	*	1	押え上げレバー	PRESSER BAR LIFTER
18	10660	*	*	1	押え上げレバーピンねじ	HINGE SCREW 4.5×32
19	10796	*	*	1	外押え	LIFTING PRESSER FOOT
20	10664	*	*	1	外押え止めねじ	SCREW 3.4×36 L=9.0
21	19425	*	*	1	横軸	LIFTING ROCK SHAFT
22	10514	*	*	2	横軸メタル	LIFTING ROCK SHAFT BASHING
23	16709	*	*	1	横軸ピンねじ	SCREW 1/4×28
24	19516	*	*	1	横軸ピンねじナツ	NUT 1/4×28
25	10728	*	*	1	横軸ピンねじ油芯	OIL WICK
26	10558C	*	*	1	くの字セット	LIFTING BELL CRANK COMPLETE
27	10558	*	*	1	くの字	LIFTING BELL CRANK
28	10557	*	*	1	くの字連結(大)	LIFTING BELL CRANK LINK
29	10556	*	*	1	くの字連結(小)	VIBRATING PRESSER BAR CONNECTING LINK
30	34713	*	*	1	中押え棒	VIBRATING PRESSER BAR
31	10554	*	*	1	中押えスプリング	VIBRATING PRESSER BAR EXTENSION SPRING
32	10553-A	*	*	1	中押えスプリング棒	VIBRATING PRESSER BAR EXTENSION
33	15080	*	*	1	中押え棒押しねじ	SCREW 5/16×24 L=16.0
34	15118	*	*	1	振れ止角玉	VIBRATING PRESSER BAR SLIDE BLOCK
35	19411C	*	*	1	中押え(組)	VIBRATING PRESSER FOOT COMPLETE
36	19411	*	*	1	中押え	VIBRATING PRESSER FOOT
37	17104	*	*	1	中押え止めねじ	PINCH SCREW 11/64×40 L=6.0
38	10548-A	*	*	1	押え棒抱き振れ止め板	LIFTING BRACKET GUIDE BLOCK
39	10519	*	*	1	止めねじ	PINCH SCREW 6.75X24 L=17.5
40	15111	*	*	1	ピン	PIN
41	19419	*	*	1	上下カム連結だるま	LIFTING ECCENTRIC CONNECTING CRANK
42	19420	*	*	1	上下カム連結だるま締めねじ	PINCH SCREW 1/4×28 L=16.0
43	10775	*	*	1	上連結ロッド段ねじ	HINGE SCREW 7/32×32
44	10703	*	*	1	上連結ロッド段ねじワッシャー	WASHER
45	10774	*	*	1	上連結ロッドパイプ	LIFTING ECCENTRIC CONNECTION COLLAR
46		*	*	1	ワッシャー	WASHER
47		*	*	1	ナツト	NUT 7/32×32
48	10185	*	*	1	外押え(1/4)	LIFTING PRESSER FOOT(1/4)
49	10285	*	*	1	中押え(1/4)	VIBRATING PRESSER FOOT(1/4)

針棒土台、連結ロツド

NEEDLE BAR ROCK FRAME、ROCK SHAFT CRANK CONNECTION

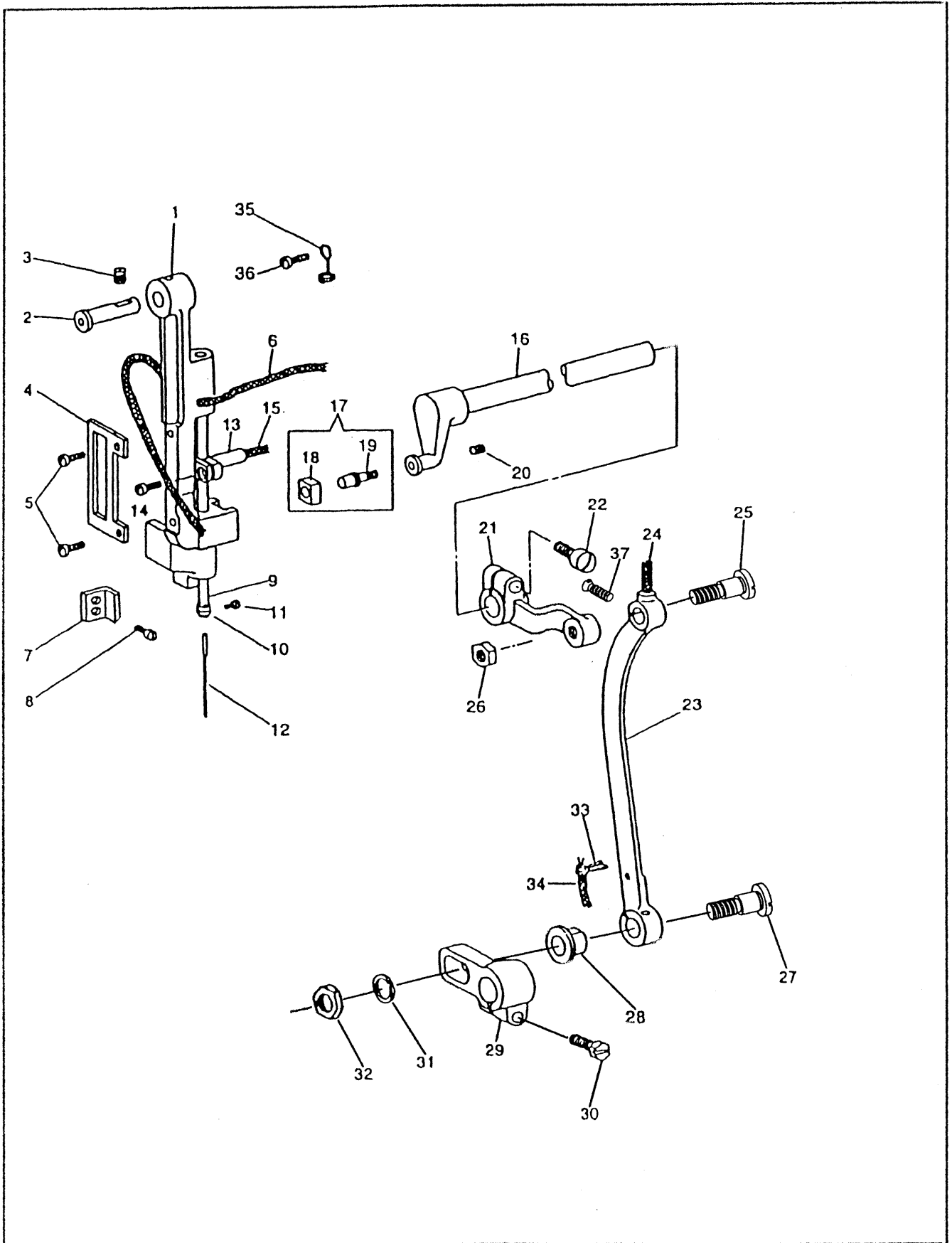

針棒土台、連結ロッド

NEEDLE BAR ROCK FRAME, ROCK SHAFT CRANK CONNECTION

NO	部品番号 PART NO	339RBL -25	255RBL -25	数量 QTY	品名	PARTS NAME
1	15110-A	*	*	1	針棒土台	NEEDLE BAR ROCK FRAME
2	11875	*	*	1	針棒土台ピン	HINGE STUD
3	10525	*	*	1	止めねじ	SET SCREW 6.75X24 L=9.0
4	15117	*	*	1	振れ止板	SLIDE BLOCK PLATE
5	8100	*	*	2	振れ止板止めねじ	SCREW 9/64X40 L=6.5
6	15031	*	*	1	針棒土台油芯	OIL WICK
7	84001-L	*	*	1	イケール	NEEDLE BAR ROCK FRAME POSITION BRACKET
8	10561	*	*	2	止めねじ	LIFTING BRACKET GUIDE SCREW 11/64X32 L=6.5
9	16703	*	*	1	針棒	NEEDLE BAR
10	15089	*	*	1	針棒糸掛	THREAD GUIDE
11	B140553	*	*	1	針止めねじ	SCREW 1/8X40 L=4.5
12	N0122	*	*	1	針	NEEDLE
13	19426	*	*	1	針棒抱き	NEEDLE BAR CONNECTING STUD
14	13365	*	*	1	針棒抱き締めねじ	PINCH SCREW M4X0.7 L=9.0
15	10726	*	*	1	針棒抱き油芯	OIL WICK
16	84002-L	*	*	1	上送り竿	NEEDLE BAR ROCK FRAME ROCK SHAFT
17	11876C	*	*	1	上送り竿角玉(組)	SLEDE BLOCK COMPLETE
18	11877	*	*	1	上送り竿角玉	SLIDE BLOCK
19	11876	*	*	1	上送り竿ピンねじ	SLIDE BLOBK STUD
20	10581	*	*	1	上送り竿ピンねじ止めねじ	SET SCREW 7/32X32 L=7.0
21	15016	*	*	1	連結	ROCK SHAFT CRANK
22	10519	*	*	1	連結締めねじ	PINCH SCREW 6.75X24 L=17.5
23		*	*	1	連結ロッド	ROCK SHIFR CRANK CONNECTION
24	10728	*	*	1	連結ロッド油芯	OIL WICK
25		*	*	1	連結ロッド皿ねじ(小)	SCREW 9/32X28 L=23.5
26	8105	*	*	1	連結ロッド皿ねじ(小)ナット	NUT 9/32X28
27		*	*	1	連結ロッド皿ねじ(大)	SCREW 5/16X28 L=29.5
28		*	*	1	送り調節パイプ	NEEDLE BAR ROCK FRAME REGULATING PIPE
29	15019	*	*	1	送り竿後だるま	FEED ROCK SHAFT CRANK
30	10754	*	*	1	送り竿後だるま締めねじ	PINCH SCREW 6.75X24 L=16
31		*	*	1	ワッシャー	WASHER
32		*	*	1	連結ロッド皿ねじ(大)ナット	NUT 5/16X28
33	10779	*	*	1	油芯押え割ピン	CLIP
34	10778	*	*	1	油芯	OLK WICK
35	4221	*	*	1	油芯押え	OLK WICK ETAINER
36	15007	*	*	1	糸調子棒(短)止めねじ	SCREW 9/64X40 L=10.0
37		*	*	2	ねじ	SCREW 9/64X40 L=12.0

大弓、押工棒大板バネ

KNEE LIFTER LIFTING LEVER、PRESSER BAR SPRING

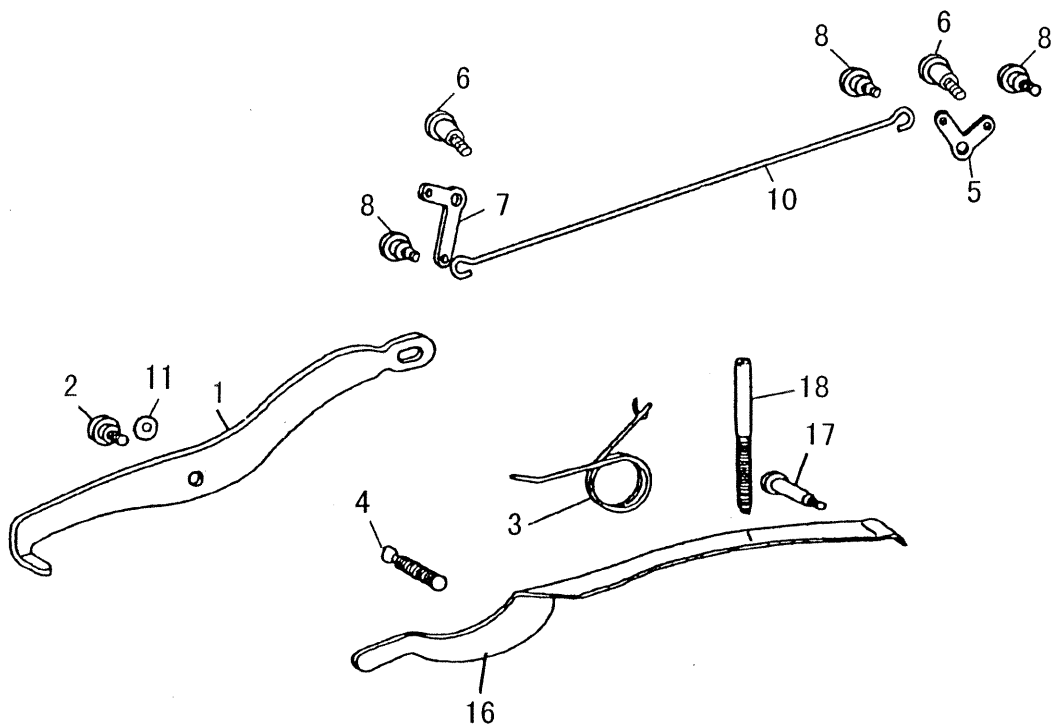

大弓、押工棒大板バネ

KNEE LIFTER LIFTING LEVER、PRESSER BAR SPRING

NO	部品番号 PART NO	339RBL -25	255RBL -25	数量 QTY	品名	PARTS NAME
1	85001-L	*	*	1	大弓	KNEE LIFTER LIFTING LEVER
2	85002-L	*	*	1	大弓止めねじ	HINGE SCREW 6.35X24
3	13059	*	*	1	弓ばね	SPRING
4	11154	*	*	1	弓ばね止めねじ	SCREW 6.75X24
5	85003-L	*	*	1	押さえレバー B	LIFTING LEVER B
6	85004-L	*	*	2	止めねじ	HINGE SCREW 6.35X24
7	85005-L	*	*	1	押さえレバー A	LIFTING LEVER A
8	85006-L	*	*	3	止めねじ	HINGE SCREW 6.35X24
9						
10	85007-L	*	*	1	レバー	LONG LEVER
11	85008-L	*	*	2	ザガネ	WASHER
12						
13						
14						
15						
16	10705	*	*	1	押え棒大板ばね	PRESSER BAR SPRING (FLAT)
17	10706	*	*	1	大板ばね受けねじ	PRESSER BAR SPRING SUPPORT SCREW
18	11156	*	*	1	大板ばね調節ねじ	PRESSER BAR SPRING REGULATING SCREW

下軸、下ベルトプーリー、送りカム

HOOK DRIVING SHAFT, SAFETY CLUTCH PULLEY, FEED DRIVING CAM

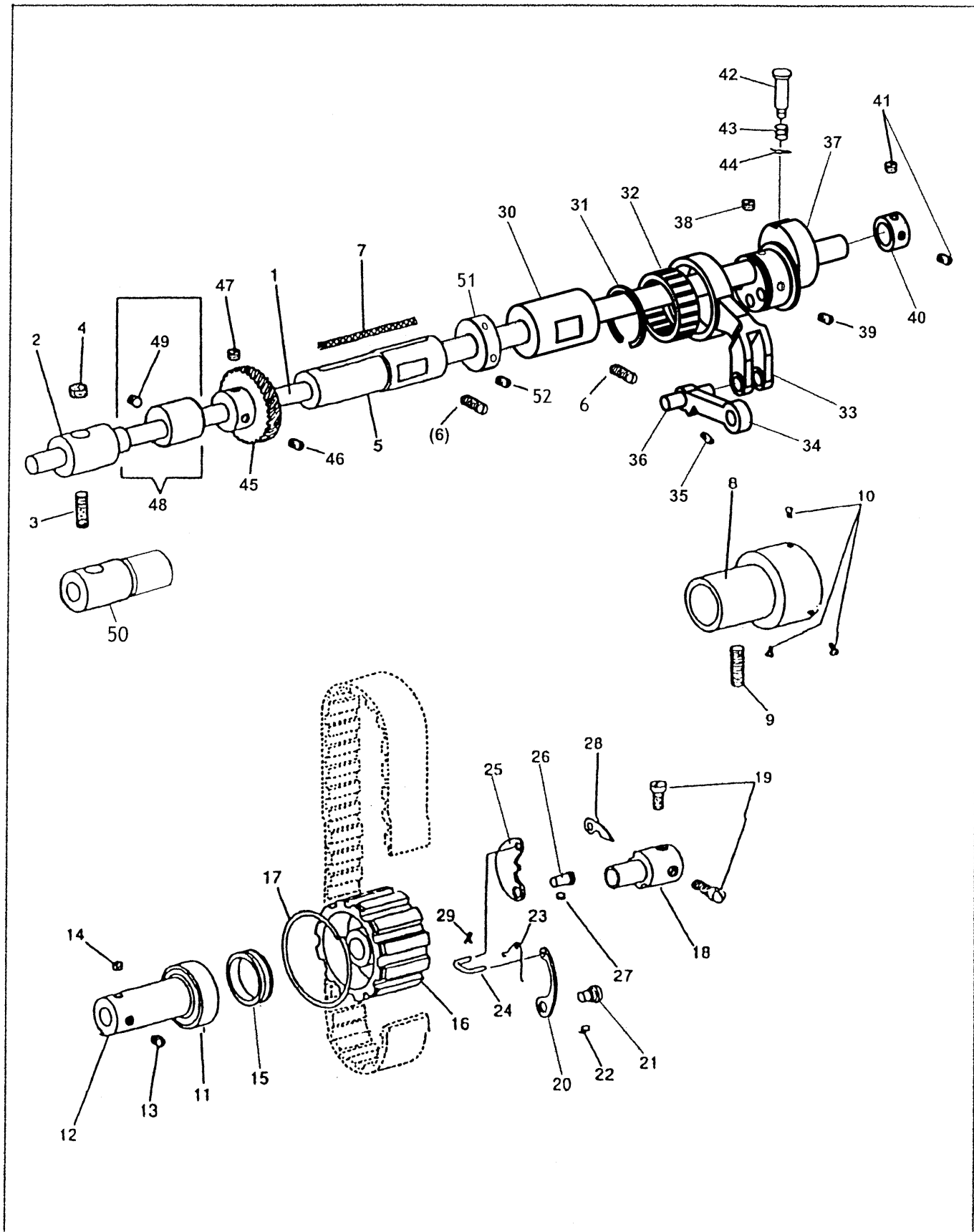

下軸、下ベルトプーリー、送りカム

HOOK DRIVING SHAFT, SAFETY CLUTCH PULLEY、FEED DRIVING CAM

NO	部品番号 PART NO	339RBL -25	255RBL -25	数量 QTY	品名	PARTS NAME
1	86001-L	*	*	1	下軸	HOOK DRIVING SHAFT
2	10782	*	*	1	下軸(前)メタル	HOOK DRIVING SHAFT BUSIING(FRONT)
3	10571	*	*	1	止めねじ	SET SCREW 6.75X24 L=20.0
4	11080	*	*	1	下軸(前)メタルフェルト	OILING FELT
5	10805	*	*	1	下軸(中)メタル	HOOK DRIVING SHAFT BUSIING(MIDDLE)
6	10522	*	*	2	止めねじ	SET SCREW 6.75X24 L=14.0
7	10729	*	*	1	メタル油芯	OIL WICK
8	30157	*	*	1	下軸ベアリングケース	HOOK DRIVING SHAFT BUSIING(BACK)
9	10571	*	*	1	止めねじ	SET SCREW 6.75X24 L=20.0
10	10609	*	*	3	清付リング止めねじ	SCREW 3.4X36 L=5.5
11	10567	*	*	1	下軸ベアリング	BALL BEARING
12	10807	*	*	1	下軸ベアリングカラー	COLLAR
13	10566	*	*	1	止めねじ	SET SCREW 1/4X32 L=5.5
14	10658	*	*	1	位置決めねじ	POSITION SCREW 1/4X32 L=5.5
15	10608	*	*	1	清付リング	BALL BEARING RETAINING WASHER
16	10810-01	*	*	1	下ベルトプーリー	SAFETY CLUTCH PULLEY
17	10574	*	*	1	プーリーリング	PULLEY SPRING FLANGE
18	10611	*	*	1	下ベルトプーリー心棒	SAFETY CLUTCH COLLAR
19	10612	*	*	2	止めねじ	SCREW 1/4X32 L=10.5
20	10615	*	*	1	下ベルトプーリー板ばね	SAFETY CLUTCH LOCKING LEVER SPRING
21	10814	*	*	1	下ベルトプーリー一段ピン	HINGE PIN
22	10581	*	*	1	下ベルトプーリー一段ピン止めねじ	SCREW 7/32X32 L=7.0
23	10619	*	*	1	下ベルトプーリースプリング	SAFE CLUTCH THROW INLATCH SPRING
24	10618	*	*	1	下ベルトプーリー小連結	SAFE CLUTCH RATCHET CONNECTING LINK
25	10616	*	*	1	下ベルトプーリー掛金	SAFE CLUTCH LOCKING LEVER
26	10613	*	*	1	下ベルトプーリー掛金ピン	HINGE STUD
27	10581	*	*	1	掛金ピン止めねじ	SCREW 7/32X32 L=7.0
28	10617	*	*	1	下ベルトプーリー小爪	SAFE CLUTCH RATCHET
29	10620	*	*	1	下ベルトプーリー割ピン	SAFE CLUTCH THROW INLATCH PIN
30		*	*	1	下軸メタル	HOOK DRIVING SHAFT BUSHING
31	10723	*	*	1	C型止メ輪	C-TYPE STOP RING
32	10722	*	*	1	軸受	BEARING
33	34007	*	*	1	送りロッド	FEED CONNECTING ROD
34	34010	*	*	1	連接棒	LINK
35	11953	*	*	1	ねじ	SCREW 7/32X32 L=5.5
36	34011	*	*	1	軸	SHAFT
37	34009	*	*	1	送りカム	FEED ECCENTRIC
38	14114	*	*	1	止めねじ	SCREW 1/4X32 L=6.5
39	14116	*	*	1	止めねじ	SCREW 1/4X32 L=9.5
40	10623	*	*	1	押しリング	COLLAR
41	10566	*	*	2	止めねじ	SET SCREW 1/4X32 L=5.5
42	34008	*	*	1	押しボタン	FEED REGULATING STUD
43	10673	*	*	1	スプリング	SPRING
44	10674	*	*	1	止めピン	PIN
45	10638	*	*	1	大ギヤ	HOOK DRIVING GFAR
46	10639	*	*	1	位置決めねじ	POSITION SCREW 1/4X32 L=8.0
47	10766	*	*	1	止めねじ	SET SCREW 1/4X32 L=7.0
48	10637	*	*	1	送り上下カムねじ付	FEED LIFTING CAM COMPLETE
49	10658	*	*	1	止めねじ	SET SCREW 1/4X32 L=5.5
50	10950	*	*	1	下軸(前)メタル	HOOK DRIVING SHAFT BUSIING(FRONT)
51	88002-L	*	*	1	カラー	COLLAR
52	10570	*	*	2	止めねじ	SET SCREW 17/64X24

針板、送り土台、送り軸

THROAT PLATE, FEED BAR, FEED ROCK SHAFT

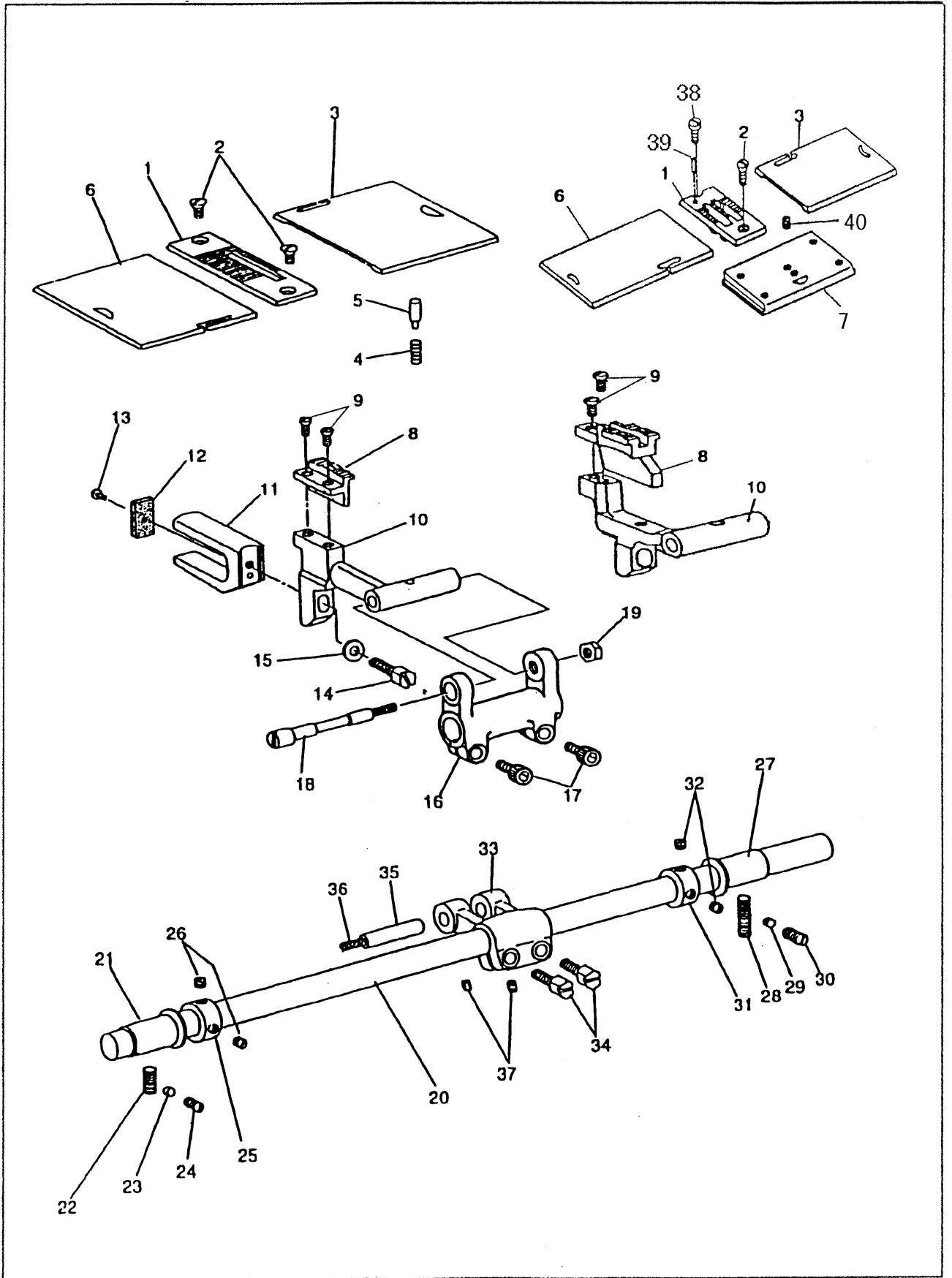

針板、送り土台、送り軸
THROAT PLATE, FEED BAR, FEED ROCK SHAFT

NO	部品番号 PART NO	339RBL -25	255RBL -25	数量 QTY	品名	PARTS NAME
1	10665		*	1	針板	THROAT PLATE
	16425	*		1	針板	THROAT PLATE
2	6031-01		*	2	針板止めねじ	SCREW 11/64X40 L=9.0
	6031-01	*		1	針板止めねじ	SCREW 11/64X40 L=9.0
3	87001-L		*	1	角板(右)	BED SLIDE (RIGHT)
	10061	*		1	角板(右)1/4	BED SLIDE (RIGHT) 1/4
4	10668	*	*	1	角板スプリング	SPRING
5	10667	*	*	1	角板ピン	PIN
6	87002-L		*	1	角板(左)	BED SLIDE (LEFT)
	10042	*		1	角板(左)1/4	BED SLIDE (LEFT) 1/4
7	11166C	*		1	差し板(組)	BED SLIDE (FRONT) COMPLETE
8	10805		*	1	送り歯	FEED DOG
	10485	*		1	送り歯	FEED DOG
9	10601	*	*	2	送り歯止めねじ	SCREW 1/8X40 L=7.0
10	10594		*	1	送り土台	FEED BAR
	11065	*		1	送り土台	FEED BAR
11	10595	*	*	1	コの字	FEED LIFTING CAM FORK
12	10596	*	*	1	コの字フェルト	OILING FELT
13	10597	*	*	1	止めねじ	SCREW 1/8X40 L=3.3
14	70129	*	*	1	コの字止めねじ	SCREW 7/32X32 L=15.0
15	10599	*	*	1	コの字ワッシャー	WASHER
16	16704	*	*	1	送り腕	FEED DRIVING ROCK FRAME
17	18065	*	*	2	送り腕締ねじ	PINCH SCREW M5X0.8 L=14.0
18	16705	*	*	1	送り土台ピンねじ	FEED BAR HINGE PIN
19	16706	*	*	1	送り土台ピンねじナット	NUT 1/4X28
20	87003-L	*	*	1	送り軸	FEED ROCK SHAFT
21	10588	*	*	1	送り軸メタル(前)	BUSHING (FRONT)
22	10522	*	*	1	メタル(前)止めねじ	SCREW 6.75X24 L=14.0
23	11068	*	*	1	ライナー	LINER
24	10761	*	*	1	メタル(前)止めねじ(補助)	SET SCREW 6.75X24 L=11.0
25	10593	*	*	1	送り軸カラー(前)	COLLER (FRONT)
26	10764	*	*	2	止めねじ	SET SCREW 6.75X24 L=4.5
27	10763	*	*	1	送り軸メタル(後)	BUSHING (BACK)
28	10571	*	*	1	メタル(後)止めねじ	SCREW 6.75X24 L=20.0
29	11068	*	*	1	ライナー	LINER
30	10525	*	*	1	メタル(後)止めねじ(補助)	SCREW 6.75X24 L=9.0
31	10593	*	*	1	送り軸カラー(後)	COLLER (BACK)
32	10764	*	*	2	止めねじ	SET SCREW 6.75X24 L=4.5
33	16708	*	*	1	送り軸前だるま	FEED ROCK SHAFT CRANK
34	19420	*	*	2	送り軸前だるま締ねじ	PINCH SCREW 1/4X28 L=16.0
35	11962	*	*	1	送り軸前だるまピン	FEED ROCK SHAFT CRANK STUD
36	11954	*	*	1	送り軸前だるまピン油芯	OIL WICK
37	11953	*	*	2	送り軸前だるまピン止めねじ	SET SCREW 7/32X32 L=5.5
38	11162	*		1	針板止めねじ	SCREW 11/64X40 L=9.0
39	11163	*		1	ピン	PIN
40	13085	*		1	差し板止めねじ	SCREW 13/64X32

バックレバー、下送りロッド

FEED REVERSING LEVER, FEED DRIVING ECCENTRIC CONNECTION

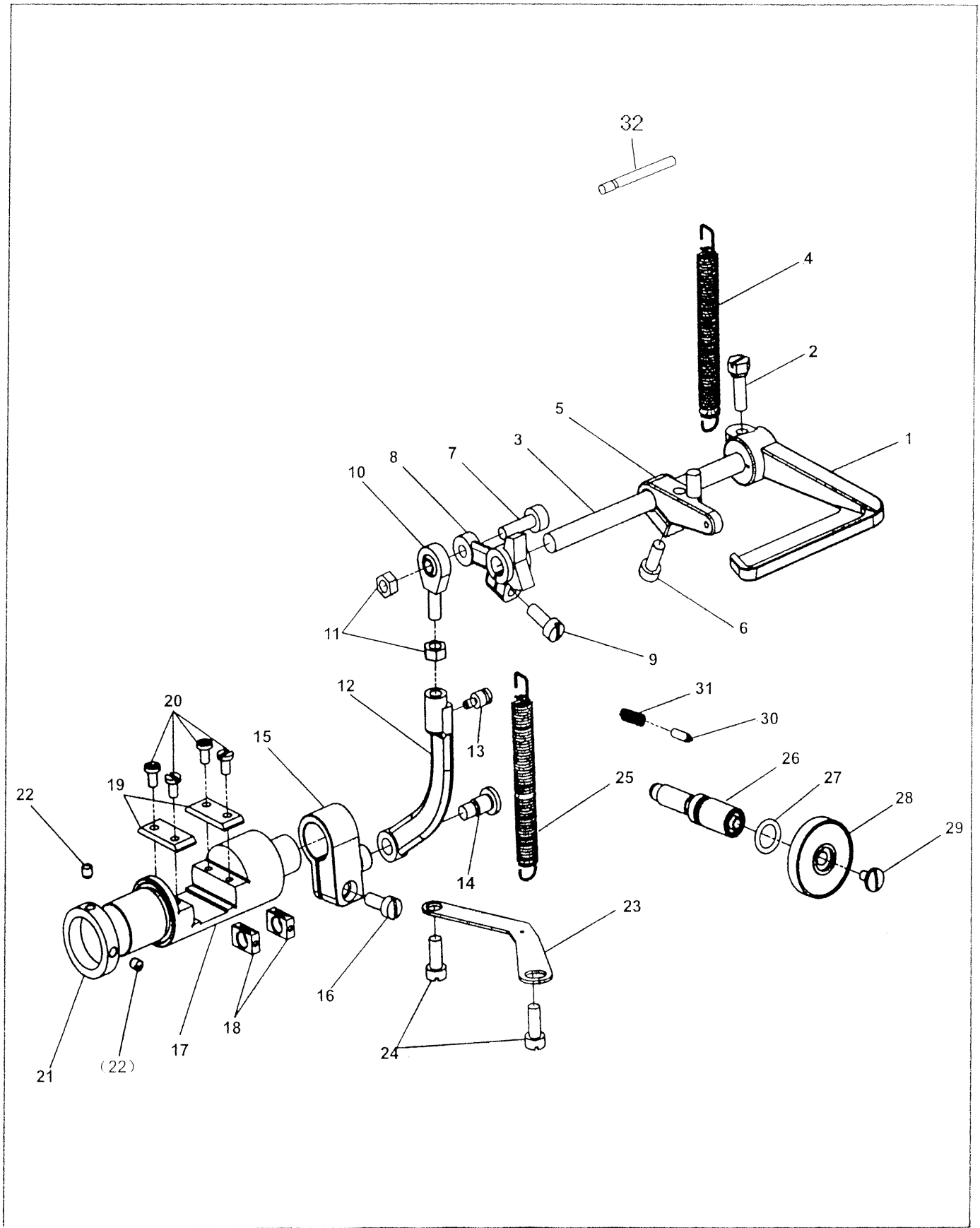

バックレバー、下送りロッド

FEED REVERSING LEVER, FEED DRIVING ECCENTRIC CONNECTION

NO	部品番号 PART NO	339RBL -25	255RBL -25	数量 QTY	品名	PARTS NAME
1	34031	*	*	1	バックレバー	FEED REVERSING LEVER
2	10845	*	*	1	バックレバー緒ねじ	SCREW 15/64X28 L=18.0
3	15208	*	*	1	バックレバー軸	FEED REVERSING LEVER SHIFT
4	34019	*	*	1	バネ	SPRING
5	30618	*	*	1	腕	ARM
6	1365	*	*	1	ねじ	PINCH SCREW 15/64X28 L=16.0
7	28152	*	*	1	軸	SHAFT
8	34027	*	*	1	送り調節カム	FEED REGULATOR CAM
9	10519	*	*	1	送り調節カムねじ	SCREW 6.75X24 L=17.5
10	11409	*	*	1	球型連結	ROUNDNESS CONNECTER
11	11412	*	*	2	ナット	NUT
12	34033	*	*	1	連接桿	LINK
13	34035	*	*	1	ねじ	SET SCREW 9/64X40 L=15.0
14	34048	*	*	1	ねじ	SCREW 5/16X24 L=16.0
15	34014	*	*	1	縫目加減腕下	REVERSE SEWING CRANK
16	1365	*	*	1	ねじ	PINCH SCREW 15/64X28 L=16.0
17	34005	*	*	1	返し台	REVERSE BLOCK
18	34012	*	*	2	角駒	SQUARE BLOCK
19	34013	*	*	2	案内板	GUIDE PLATE
20	15055	*	*	4	ブラマイねじ	SCREW 11/64X40 L=8.0
21	34006	*	*	1	カラー	COLLAR
22	11953	*	*	2	止めねじ	SET SCREW 7/32X32 L=5.5
23	34044	*	*	1	案内板	GUIDE PLATE
24	15060	*	*	2	ねじ	SCREW 5/16X24 L=16.0
25	34040	*	*	1	バネ	SPRING
26	34028	*	*	1	送り調節ネジ	SCREW BAR
27	18420	*	*	1	Oリング	O-RING
28	34029	*	*	1	ダイヤル	DIAL
29	18417	*	*	1	ねじ	SCREW 11/64X32 L=8.0
30	18418	*	*	1	ピン	PIN
31	15729	*	*	1	ツル巻バネ	SRRING
32	88001-L	*	*	1	ピン	PIN

カマ土台 (右)、カマ
 HOOK SADDLE (RIGHT), HOOK

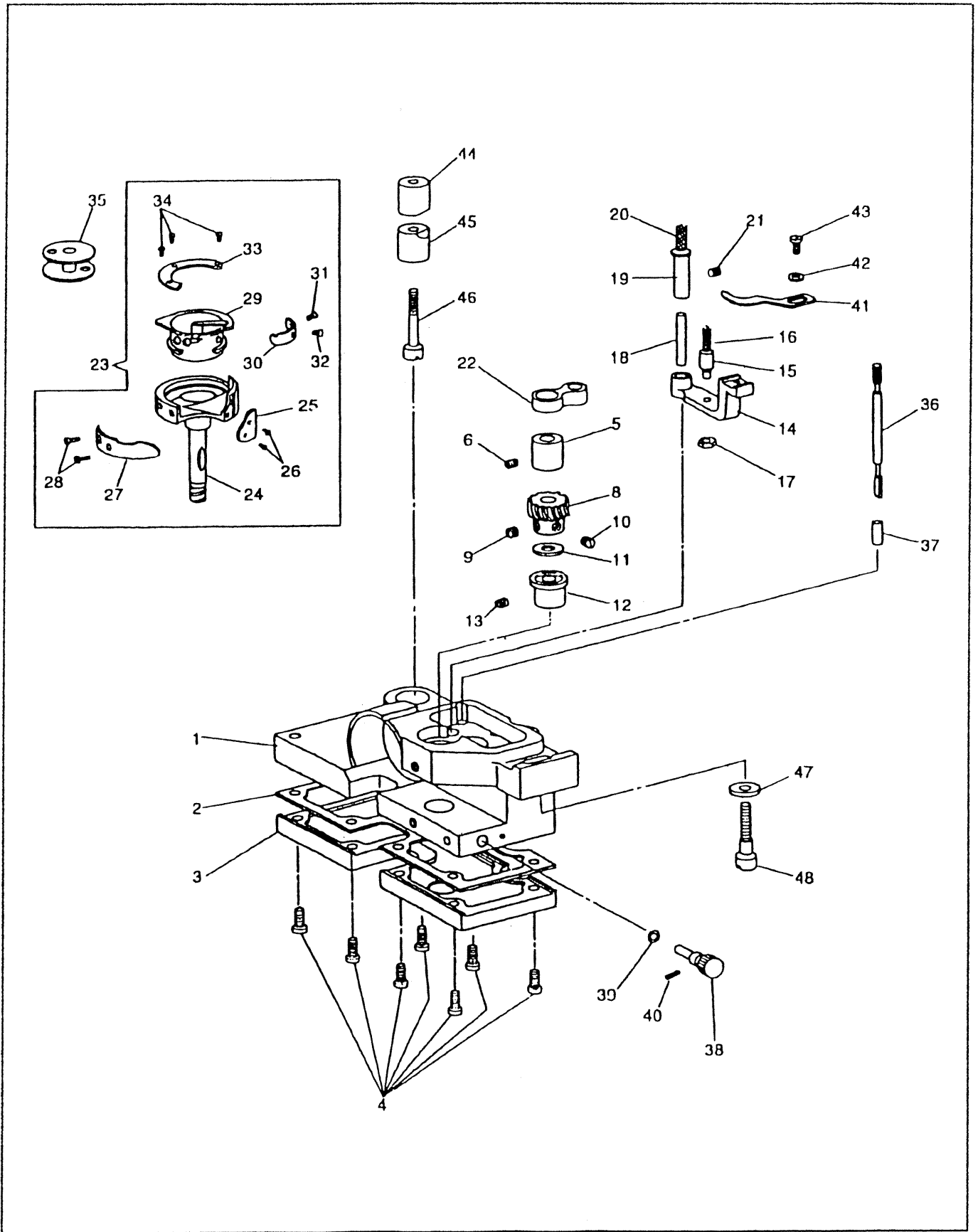

カマ土台(右)、カマ
HOOK SADDLE(RIGHT)、HOOK

NO	部品番号 PART NO	339RBL -25	255RBL -25	数量 QTY	品名	PARTS NAME
1	15090	*	*	1	カマ土台(右)	HOOK SADDLE (RIGHT)
2	15092	*	*	1	シートパッキング	PACKING
3	15091	*	*	1	カマ土台油タンク(右)	OIL PRSERVIOR (RIGHT)
4	15007	*	*	7	止めねじ	SCREW 9/64×40 L=10.0
5	15095	*	*	1	カム土台メタル(上)	BUSHING (UPPER)
6	11176	*	*	1	止めねじ	SCREW 7/32×32 L=5.5
7						
8	10657	*	*	1	小ギヤー	HOOK DRIVING PINION (SPIRAL)
9	10658	*	*	1	位置決めねじ	POSITION SCREW 1/4×32 L=5.5
10	10767	*	*	1	止めねじ	SET SCREW 1/4×32 L=4.5
11	10644	*	*	1	ワッシャー	WASHER
12	15096	*	*	1	カメ土台メタル(下)	BUSHING (LOWER)
13	11176	*	*	1	止めねじ	SCREW 7/32×32 L=5.5
14	15049	*	*	1	オープナー土台	BOBBIN CASE OPENER LEVER
15	10651	*	*	1	めがねピン	OPENER LEVER DRIVING SCREW STUD
16	10727	*	*	1	めがねピンフェルト	FELT
17	10652	*	*	1	ナット	NUT 11/64×40
18	11137	*	*	1	オープナー土台ピンパイプ	HINGE STUD OIL FURNISHING TUBE
19	15050	*	*	1	オープナー土台ピン	OPERER LEVER HINGE STUD
20	10727	*	*	1	オープナー土台ピンフェルト	FELT
21	10573	*	*	1	止めねじ	SET SCREW 7/32×32 L=11.0
22	15051	*	*	1	カマ連結メガネ	BOBBIN CASE LEVER LINK
23	15040	*	*	1	カマ(組)	HOOK COMPLETE
24	16407-01	*	*	1	外カム	HOOK
25	16407-07	*	*	1	糸案内板	THREAD GUIDE
26	16407-08	*	*	2	止めねじ	SCREW
27	16407-05	*	*	1	針受板	NEEDLE GUARD
28	16407-06	*	*	2	止めねじ	SCREW
29	15040-02	*	*	1	内力マ	BOBBIN CASE COMPLETE
30	15040-10	*	*	1	系調子バネ	BOBBIN CASE TENSION SPRING
31	16407-11	*	*	1	系調子バネ止めねじ	SET SCREW
32	16407-12	*	*	1	系調子バネ調子ねじ	TENSION REGULATING SCREW
33	15040-03	*	*	1	内力マ押え	HOOK GIB
34	16407-04	*	*	3	内力マ押え止めねじ	HOOK GIB SCREW
35	15041	*	*	1	ボビン	BOBBIN
36	15052	*	*	1	オイルゲージ	OIL GAUGE
37	11131	*	*	1	オイルゲージ案内パイプ	OIL GAUGE GUIDE TUBE
38	15093	*	*	1	油調節ダイヤル	OIL REGULATING SCREW
39	15094	*	*	1	Oリング	O-RING
40	10629	*	*	1	油調節ダイヤル止めねじ	SET SCREW 1/8×40 L=8.0
41	15048	*	*	1	ボビンケースオープナー	BOBBIN CASE LEVER
42	10677	*	*	1	ワッシャー	WASHER
43	10650	*	*	1	オープナー土台止めねじ	SCREW 3.4×36 L=6.0
44	11145	*	*	1	カマ土台締付けカラー(上)	PINCH SLEEVE (UPPER)
45	11146	*	*	1	カマ土台締付けカラー(下)	PINCH SLEEVE (UPPER)
46	11144	*	*	1	カマ土台締付けねじ	PINCH SLEEVE SCREW 7/32×32 L=32.0
47	10647	*	*	1	ワッシャー	WASHER
48	10646	*	*	1	カマ土台止めねじ	SCREW 6.75×24 L=28.0

カマ土台 (左)、カマ
 HOOK SADDLE (LEFT), HOOK

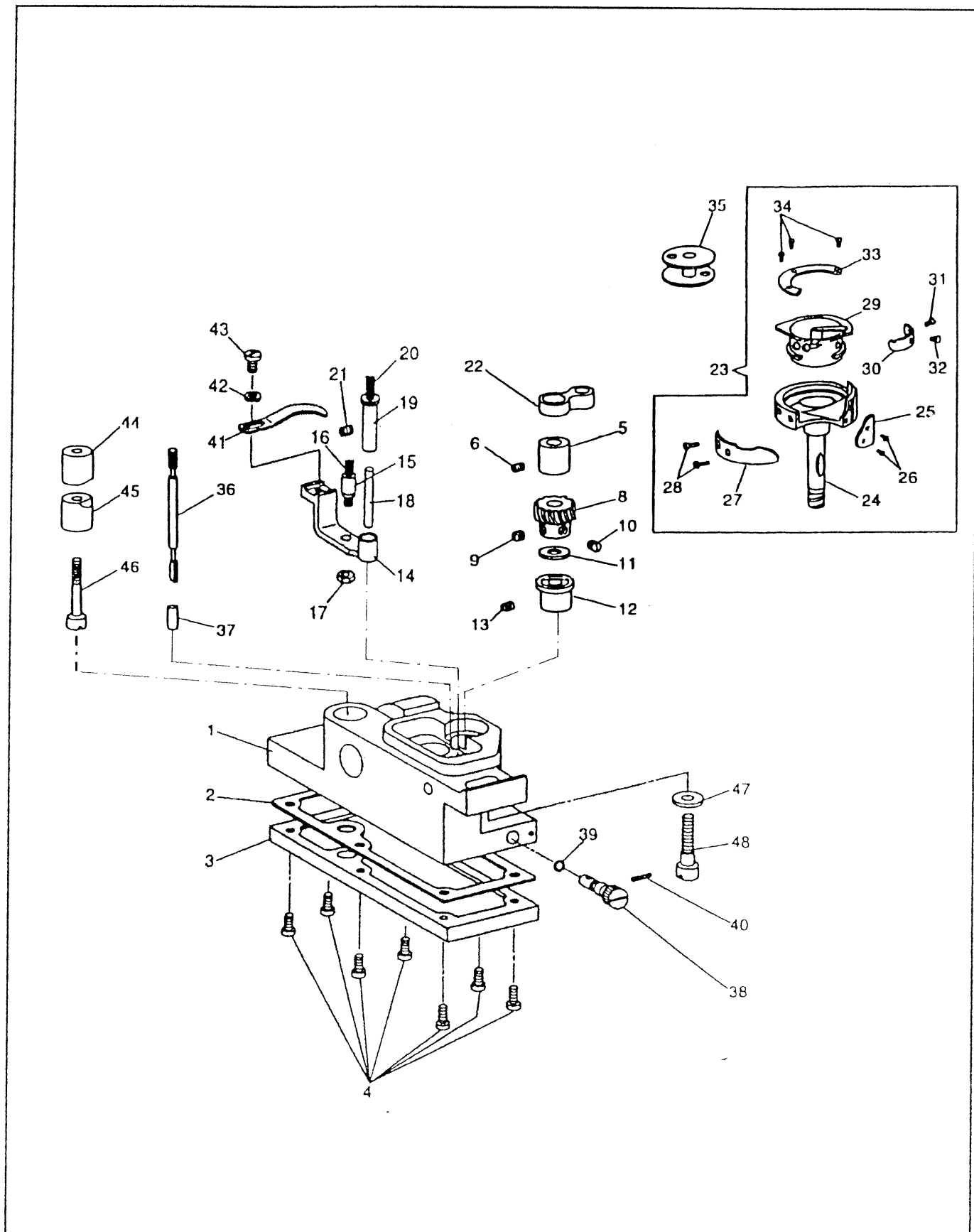

カマ土台(左)、カマ
HOOK SADDLE (LEFT)、HOOK

NO	部品番号 PART NO	339RBL -25	255RBL -25	数量 QTY	品名	PARTS NAME
1	15520	*		1	カマ土台(左)	HOOK SADDLE (LEFT)
2	15092	*		1	シートパッキング	PACKING
3	15521	*		1	カマ土台油タンク(左)	OIL PRSERVIOR (LEFT)
4	15007	*		7	止めねじ	SCREW 9/64×40 L=10.0
5	15095	*		1	カム土台メタル(上)	BUSHING (UPPER)
6	11176	*		1	止めねじ	SCREW 7/32×32 L=5.5
7						
8	10657	*		1	小ギヤー	HOOK DRIVING PINION (SPIRAL)
9	10658	*		1	位置決めねじ	POSITION SCREW 1/4×32 L=5.5
10	10767	*		1	止めねじ	SET SCREW 1/4×32 L=4.5
11	10644	*		1	ワッシャー	WASHER
12	15096	*		1	カメ土台メタル(下)	BUSHING (LOWER)
13	11176	*		1	止めねじ	SCREW 7/32×32 L=5.5
14	15049	*		1	オープナー土台	BOBBIN CASE OPENER LEVER
15	10651	*		1	めがねピン	OPENER LEVER DRIVING SCREW STUD
16	10727	*		1	めがねピンフェルト	FELT
17	10652	*		1	ナット	NUT 11/64×40
18	11137	*		1	オープナー土台ピンパイプ	HINGE STUD OIL FURNISHING TUBE
19	15050	*		1	オープナー土台ピン	OPERER LEVER HINGE STUD
20	10727	*		1	オープナー土台ピンフェルト	FELT
21	10573	*		1	止めねじ	SET SCREW 7/32×32 L=11.0
22	15051	*		1	カマ連結メがネ	BOBBIN CASE LEVER LINK
23	15040	*		1	カマ(組)	HOOK COMPLETE
24	16407-01	*		1	外カム	HOOK
25	16407-07	*		1	糸案内板	THREAD GUIDE
26	16407-08	*		2	止めねじ	SCREW
27	16407-05	*		1	針受板	NEEDLE GUARD
28	16407-06	*		2	止めねじ	SCREW
29	15040-02	*		1	内カム	BOBBIN CASE COMPLETE
30	15040-10	*		1	系調子バネ	BOBBIN CASE TENSION SPRING
31	16407-11	*		1	系調子バネ止めねじ	SET SCREW
32	16407-12	*		1	系調子バネ調子ねじ	TENSION REGULATING SCREW
33	15040-03	*		1	内カム押え	HOOK GIB
34	16407-04	*		3	内カム押え止めねじ	HOOK GIB SCREW
35	15041	*		1	ボビン	BOBBIN
36	15052	*		1	オイルゲージ	OIL GAUGE
37	11131	*		1	オイルゲージ案内パイプ	OIL GAUGE GUIDE TUBE
38	15093	*		1	油調節ダイヤル	OIL REGULATING SCREW
39	15094	*		1	Oリング	O-RING
40	10629	*		1	油調節ダイヤル止めねじ	SET SCREW 1/8×40 L=8.0
41	15048	*		1	ボビンケースオープナー	BOBBIN CASE LEVER
42	10677	*		1	ワッシャー	WASHER
43	10650	*		1	オープナー土台止めねじ	SCREW 3.4×36 L=6.0
44	11145	*		1	カマ土台締付けカラー(上)	PINCH SLEEVE (UPPER)
45	11146	*		1	カマ土台締付けカラー(下)	PINCH SLEEVE (UPPER)
46	11144	*		1	カマ土台締付けねじ	PINCH SLEEVE SCREW 7/32×32 L=32.0
47	10647	*		1	ワッシャー	WASHER
48	10646	*		1	カマ土台止めねじ	SCREW 6.75×24 L=28.0

調子板
TENSION

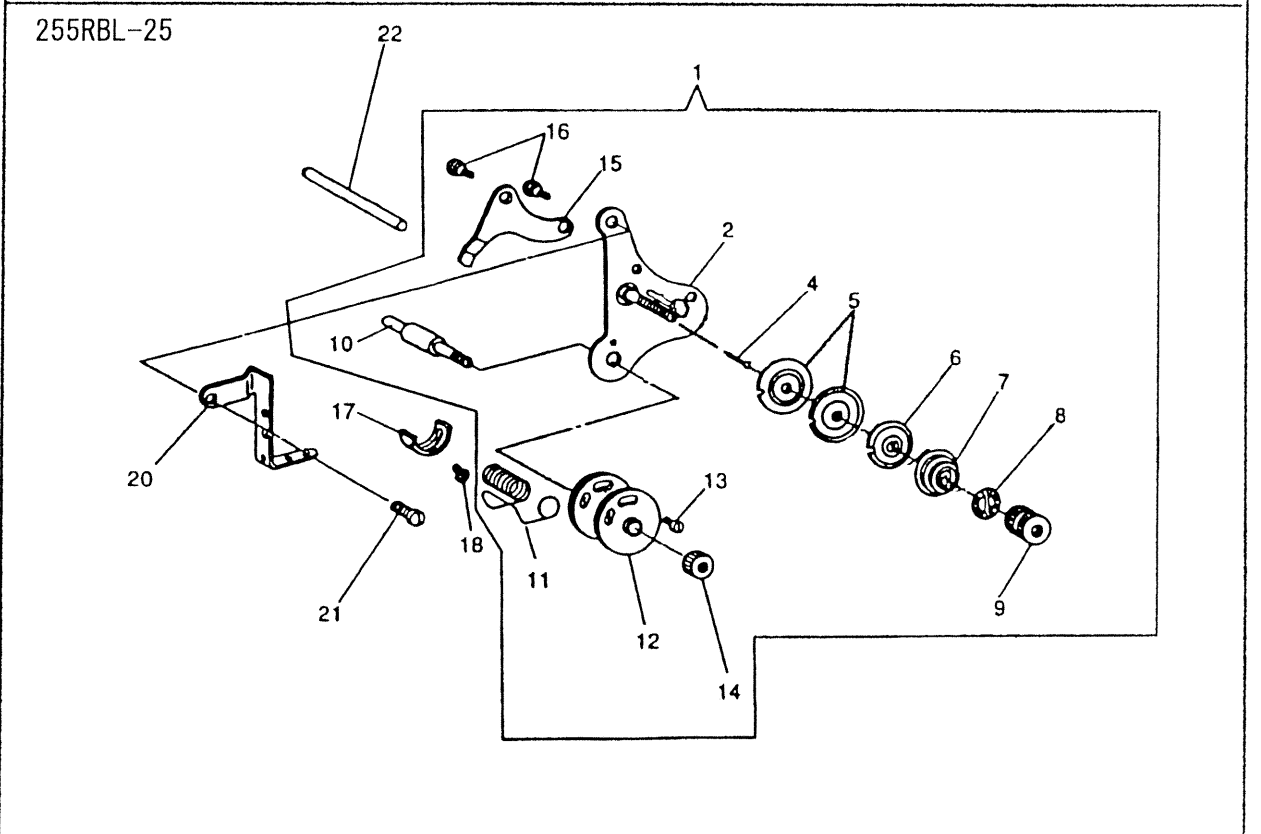
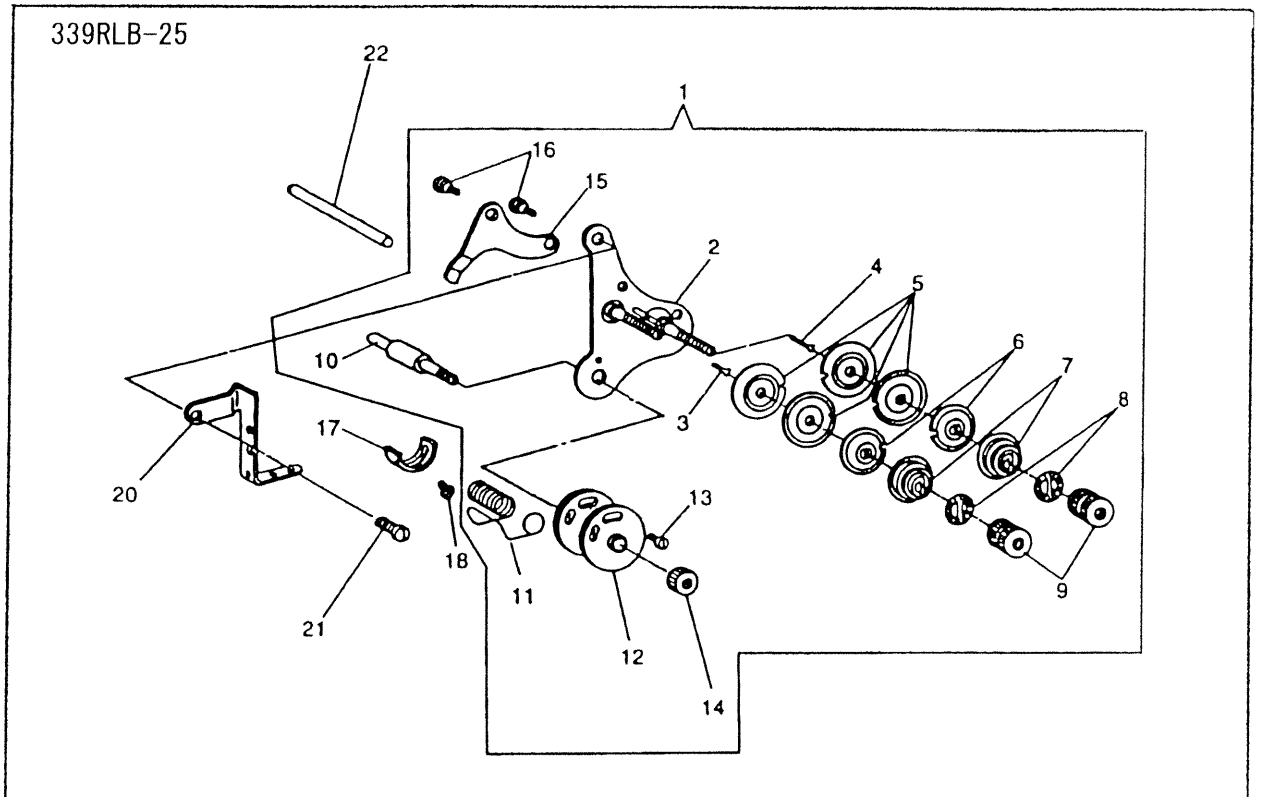

調子板
TENSION

NO	部品番号 PART NO	339RBL -25	255RBL -25	数量 QTY	品名	PARTS NAME
1	10961C-A	*	*	1	調子板組 (φ1.4)	TENSION BRACKET COMPLETE
2	19421		*	1	調子板	TENSION BRACKET
2	10961	*		1	調子板	TENSION BRACKET
3	10957	*		1	糸ゆるめ段ピン	TENSION RELEASE PIN
4	10793		*	1	糸ゆるめ段ピン(長)	TENSION RELEASE PIN (LONG)
4	10952	*		1	糸ゆるめ段ピン(長)	TENSION RELEASE PIN (LONG)
5	19531		*	2	調子皿	TENSION DISC
5	19531	*		4	調子皿	TENSION DISC
6	19532		*	1	丸一皿	TENSION RELEASE WASHER
6	19532	*		2	丸一皿	TENSION RELEASE WASHER
7	19533		*	1	渦巻スプリング (φ1.4)	TENSION SPRING
7	19533	*		2	渦巻スプリング (φ1.4)	TENSION SPRING
8	28206		*	1	ローレットストッパー	NUT WASHER
8	28206	*		2	ローレットストッパー	NUT WASHER
9	19513		*	1	ローレットナット	NUT 1/4×40
9	19513	*		2	ローレットナット	NUT 1/4×40
10	19512		*	1	糸調子棒 (短)	THREAD CONTROLLER STUD
10	10962	*		1	糸調子棒 ()	THREAD CONTROLLER STUD
11	10689		*	1	糸引スプリング	THREAD CONTROLLER SPRING
11	10953	*		1	糸引スプリング	THREAD CONTROLLER SPRING
12	10694		*	1	二重皿	THREAD CONTROLLER DISC
12	10694	*		2	二重皿	THREAD CONTROLLER DISC
13	B118319		*	1	二重皿止めねじ	SCREW 3/32×56 L=12.2
13	B144682	*		1	二重皿止めねじ	SCREW 3/32×56 L=12.2
14	19534	*	*	1	ローレットナット	NUT
15	10678	*	*	1	糸ゆるめ板	TENSION RELEASE PLATE
16	19422	*	*	2	糸ゆるめ板段ねじ	SCREW
17	10690	*	*	1	スプリング受	THREAD CONTROLLER SPRING STOP
18	10650	*	*	1	スプリング受止めねじ	SCREW 3.4×36 L=6.0
19						
20	15062		*	1	大糸掛	THREAD RETAINER
20	15517	*		1	大糸掛	THREAD RETAINER
21	15055	*	*	1	大糸掛止めねじ	SCREW 11/64×32 L=9.0
22	10720	*	*	1	糸ゆるめピン(長)	TENSION RELEASE PLATE ROD

給油
LUBRICATION

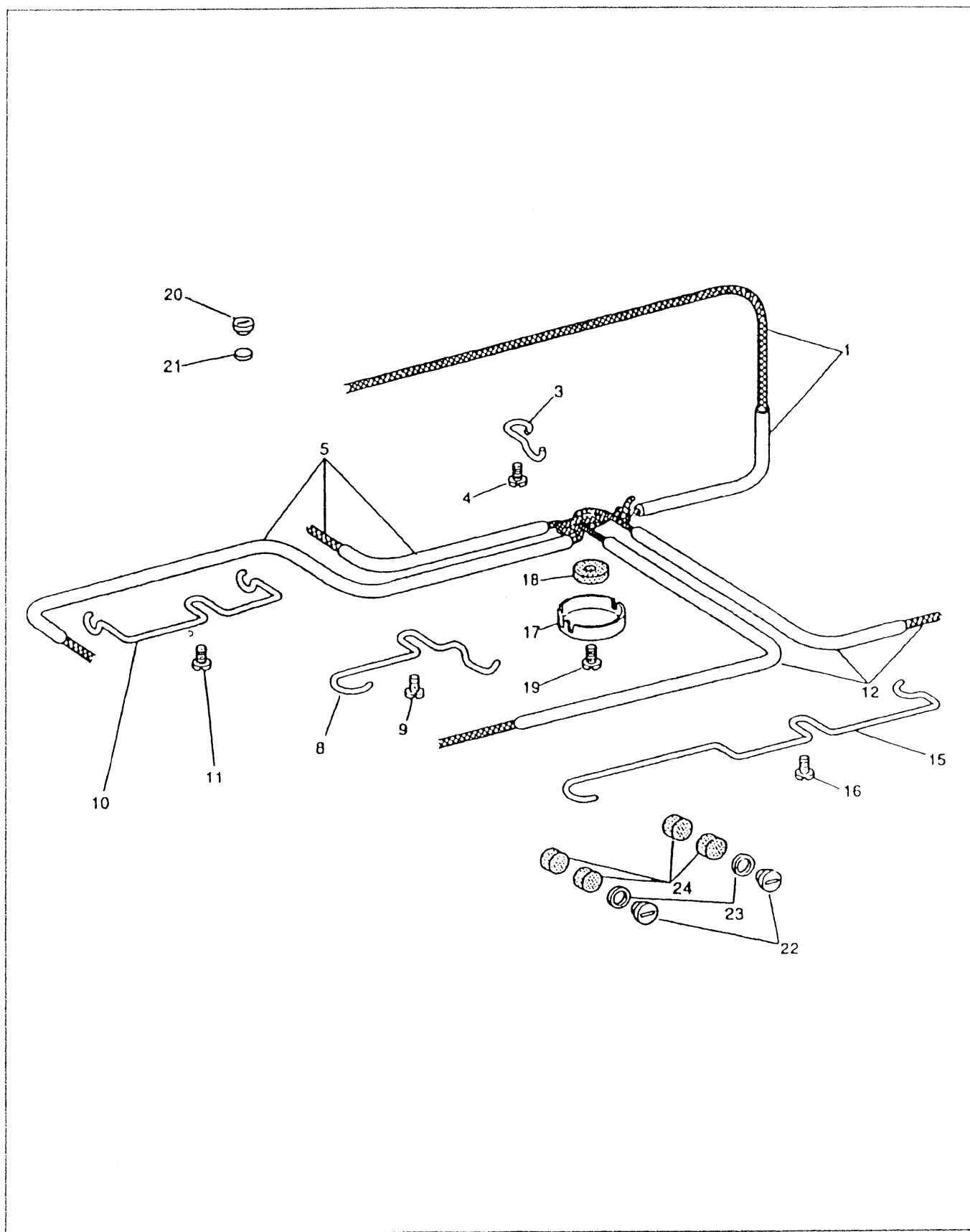

給油
LUBRICATION

NO	部品番号 PART NO	339RBL -25	255RBL -25	数量 QTY	品名	PARTS NAME
1	15063C	*	*	1	ビニールチューブ(組)	OIL TUBE AND OIL WICK
3	15087	*	*	1	ビニールチューブ押え(A)	RETAINER
4	6333	*	*	1	止めねじ	SCREW 9/64X40 L=6.5
5	15067C	*	*	1	ビニールチューブ(組)	OIL TUBE AND OIL WICK
8	15088	*	*	1	ビニールチューブ押え(B)	RETAINER
9	6333	*	*	1	止めねじ	SCREW 9/64X40 L=6.5
10	15085	*	*	1	ビニールチューブ押え(C)	RETAINER
11	6333	*	*	1	止めねじ	SCREW 9/64X40 L=6.5
12	15064C	*	*	1	ビニールチューブ(組)	OIL TUBE AND OIL WICK
15	15097	*	*	1	ビニールチューブ押え(D)	RETAINER
16	6333	*	*	1	止めねじ	SCREW 9/64X40 L=6.5
17	15077	*	*	1	ベッド油タンク	BED OIL TUBE CLAMP
18	11106	*	*	1	油タンクフェルト	OIL FELT
19	11108	*	*	1	止めねじ	SCREW 1/4X32 L=13.0
20	11085	*	*	1	下軸メタル油栓	OIL STOP SCREW 7/16X28
21	11069	*	*	1	下軸メタルフェルト	OIL FELT
22	11070	*	*	2	送り竿メタル油栓	OIL STOP SCREW 7/16X28
23	11071	*	*	2	油栓パッキン	PACKING
24	11069	*	*	4	送り竿メタルフェルト	OIL FELT

附属品
ACCESSORIES AND ATTACHMENTS

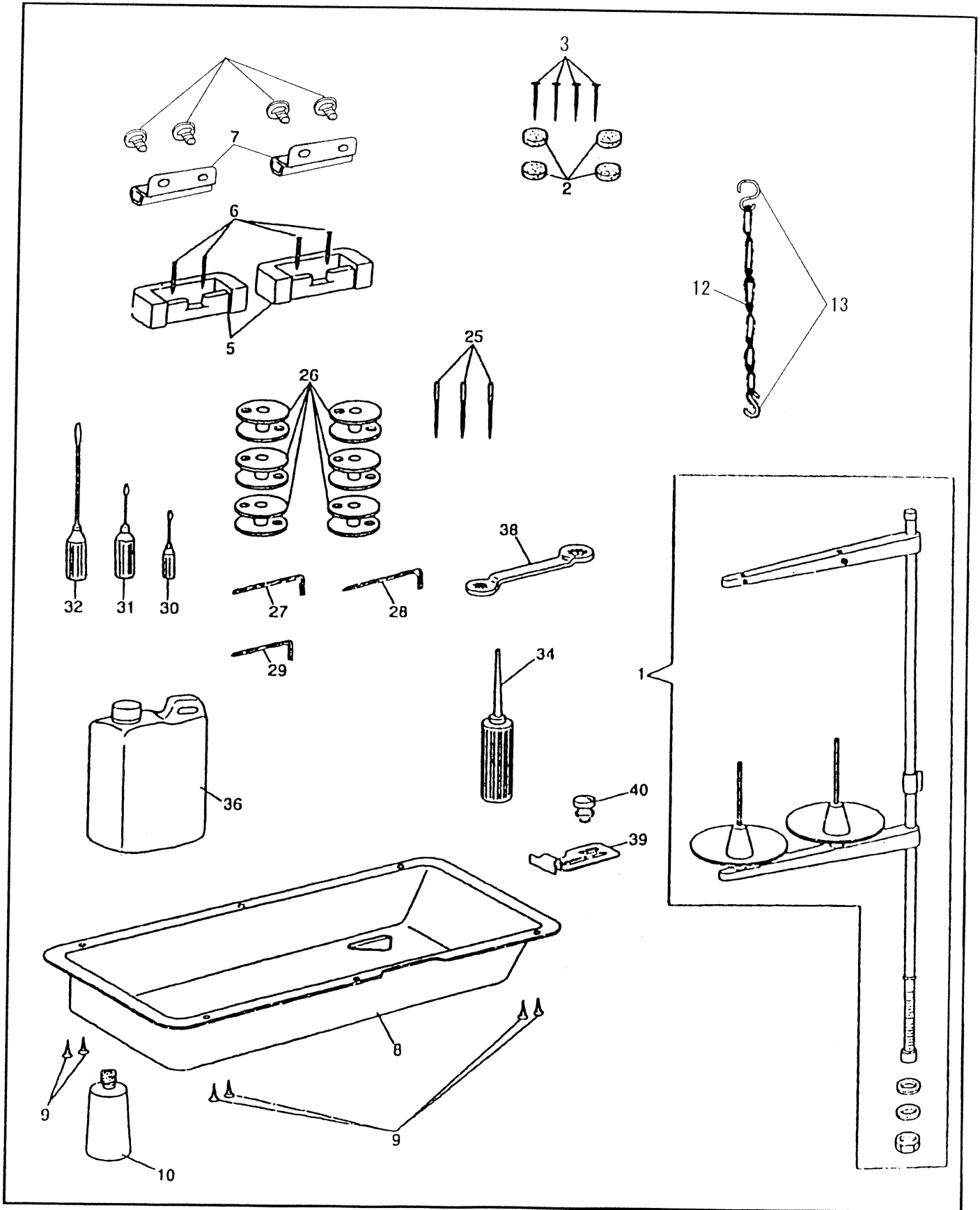

From the library of: Diamond Needle Corp

附属品

ACCESSORIES AND ATTACHMENTS

NO	部品番号 PART NO	339RBL -25	255RBL -25	数量 QTY	品名	PARTS NAME
1	35254	*	*	1	系立てセット	THREAD UNWINDER COMPLETE
2	11887	*	*	4	ミシン受	MACHINE REST
4	6055	*	*	4	釘	NAIL
5	11886	*	*	2	ミシンヒンジ受	MACHIN HINGE CONNECTION CUSHION
6	6055	*	*	4	釘	NAIL
7	11885	*	*	2	ミシン ヒンジ	MACHIN HINGE CONNECTION
8	15080	*	*	1	油受け	DRIP
9	15081	*	*	10	木ねじ	DRIP PAN NAIL
10	15082	*	*	1	油びん	DRIP PAN DRAIN JAR
11	10735	*	*	1	ひざ上げセット	KNEE LIFTER COMPLETE
12	81301-L	*	*	1	鏈	CHAIN BELT
13	81302-L	*	*	1	クリーク	POTHOOK
25	N0122	*	*	3	針	NEEDLE
26	15041	*	*	4	ボビン	BOBBIN
27	8121	*	*	1	ドライバー(小)	SCREW DRIVER (SMALL)
28	8120	*	*	1	ドライバー(中)	SCREW DRIVER (MIDDLE)
29	8118	*	*	1	ドライバー(大)	SCREW DRIVER (LARGE)
30	10747	*	*	1	六角レンチ(1/16インチ)	WRENCH
31	11487	*	*	1	六角レンチ(3ミリ)	WRENCH
32	11969	*	*	1	六角レンチ(2.5ミリ)	WRENCH
34	8125	*	*	1	油差し	OILER
36	11193	*	*	1	油	OIL
37						
38	10748	*	*	1	メガネレンチ	DOUBLE HEAD WRENCH

別売品

PARTS AVAILBLE AT EXTRA CHARGE

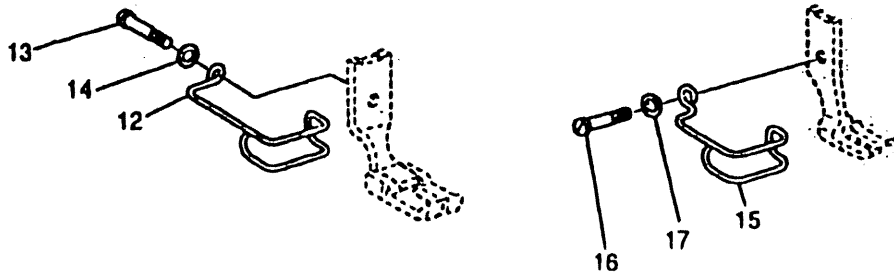
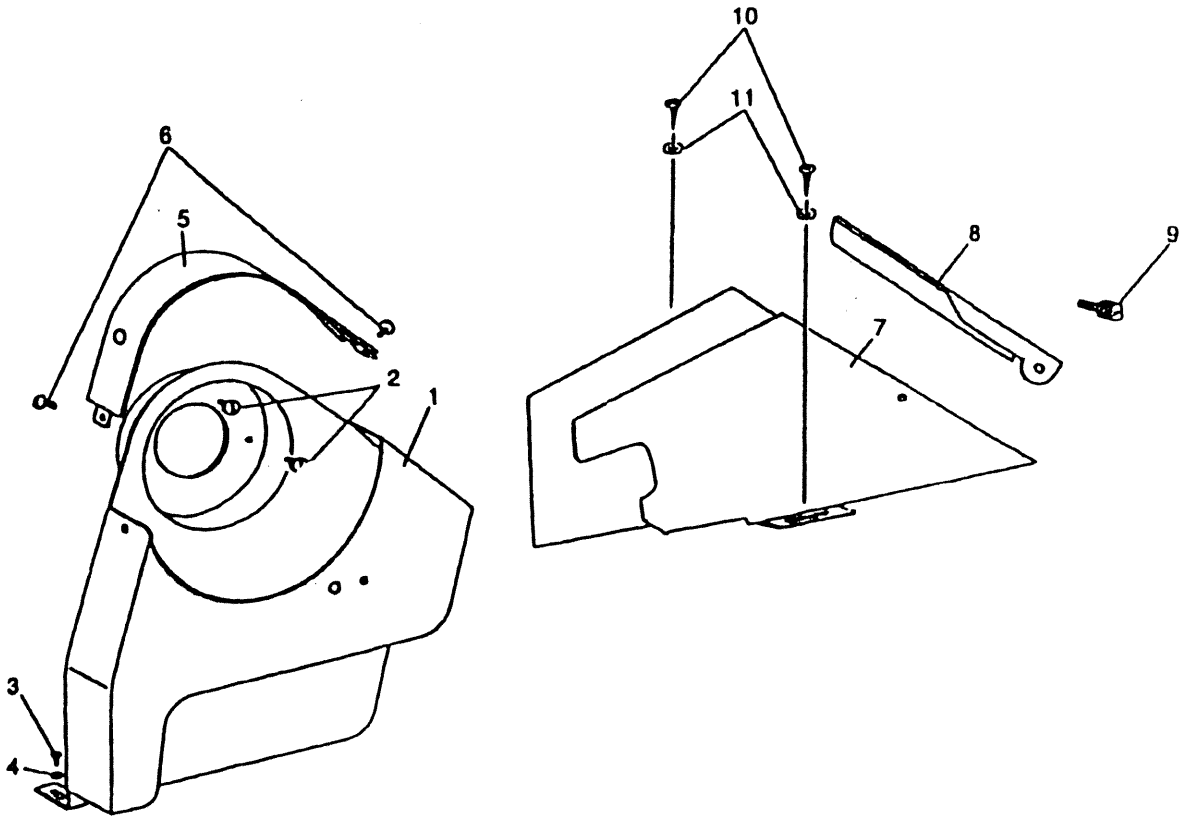

別売品

PARTS AVAILABLE AT EXTRA CHARGE

NO	部品番号 PART NO	339RBL -25	255RBL -25	数量 QTY	品名	PARTS NAME
1	15098	*	*	1	ベルトガード	BELT GUARD
2	11162	*	*	2	止めねじ(上)	SCREW 3.4X36 L=5.4
3	10650	*	*	1	止めねじ(下)	SCREW 3.4X36 L=6.0
4	11142	*	*	1	ワッシャー	WASHER
5	15099	*	*	1	ベルトガード(上)カバー	BELT GUARD (TOP) COVER
6	12418	*	*	2	止めねじ	SCREW 13/64X32 L=9.0
7	15121	*	*	1	ベルトガード(下)カバー	BELT GUARD (BOTTOM) COVER
8	15122	*	*	1	ベルトガード(下)カバー(小)	BELT GUARD (BOTTOM) COVER (SMALL)
9	11830	*	*	1	止めねじ	SCREW 9/64X40
10	15081	*	*	2	木ねじ	SCREW
11	16287	*	*	2	ワッシャー	WASHER
15	10937-01	*	*	1	フィンガーガード	FINGER GUARD
16	10749	*	*	1	止めねじ	SCREW 3.4X36 L=11.0
17	10677	*	*	1	ワッシャー	WASHER